

SANTOMAS

COMMERCE PARK

Santa Clara, California

San Tomas
Commerce Park



- ← 2900 - 2960
- ↑ 2962 - 3026
- 3028 - 3056
- ↑ 3058 - 3074
- ← Leasing Office

SANTOMAS COMMERCE PARK

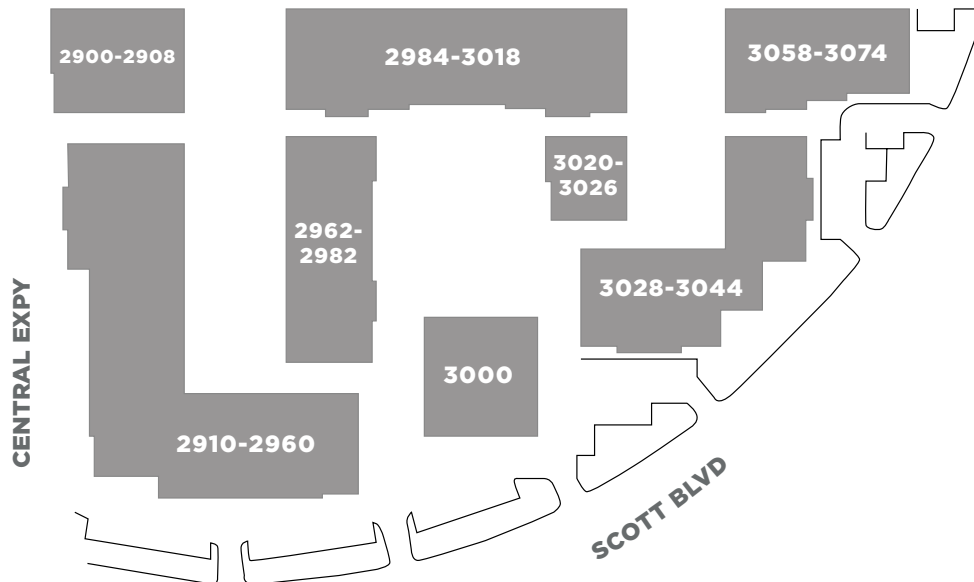

HIGHLIGHTS

- Multi-Tenant Office, R&D and Industrial Business Park
- Excellent Santa Clara Location on Scott Boulevard and Central Expressway
- Suite Sizes Range from ± 545 SF to $\pm 6,180$ SF
- Move-In Ready Suites Available for Immediate Occupancy
- On-Site Restaurant and Property Management
- Flexible Layouts Include a Combination of Office, Lab and Warehouse
- Grade Level Loading
- Comcast and AT&T Fiber Internet Service Available
- Low Electrical Costs Through Silicon Valley Power
- 2.5/1,000 Parking Ratio

AVAILABILITY

| ADDRESS | RSF | COMMENTS |
|---------------------------------|----------|--------------------------------------|
| 3000 Scott Blvd, Ste. 201 | 545 SF | 100% Office |
| 3000 Scott Blvd, Ste. 116 | 594 SF | 100% Office |
| 3000 Scott Blvd, Ste. 108 | 674 SF | 100% Office |
| 3028-B Scott Blvd | 820 SF | 100% Office |
| 3000 Scott Blvd, Ste. 111 | 986 SF | 100% Office |
| 3000 Scott Blvd, Ste. 204 | 1,165 SF | 100% Office |
| 3000 Scott Blvd, Ste. 216 | 1,346 SF | 100% Office |
| 2934 Scott Blvd | 1,410 SF | 25% Office / 65% Lab / 10% Warehouse |
| 3070 Scott Blvd | 1,660 SF | 75% Office / 20% Warehouse / 5% Lab |
| 2962 Scott Blvd | 1,680 SF | 60% Office / 30% Lab / 10% Warehouse |
| 3050 Scott Blvd | 1,740 SF | 40% Office / 60% Warehouse |
| 2968 Scott Blvd | 1,780 SF | 50% Office / 25% Lab / 25% Warehouse |
| 2980 Scott Blvd | 1,780 SF | 60% Office / 30% Lab / 10% Warehouse |
| 2970 Scott Blvd | 1,820 SF | 20% Office / 60% Lab / 20% Warehouse |
| 2972 Scott Blvd | 1,820 SF | 45% Office / 40% Lab / 15% Warehouse |
| 2982 Scott Blvd | 1,830 SF | 75% Office / 10% Lab / 15% Warehouse |
| 2958 Scott Blvd | 1,918 SF | 40% Office / 60% Warehouse |
| 3016 Scott Blvd | 1,940 SF | 50% Office / 15% Lab / 35% Warehouse |
| 2996 Scott Blvd | 1,980 SF | 50% Office / 25% Lab / 25% Warehouse |
| 3032 Scott Blvd | 2,030 SF | 40% Office / 10% Lab / 50% Warehouse |
| 3012 Scott Blvd | 2,060 SF | 40% Office / 60% Warehouse |
| 3006 Scott Blvd | 2,063 SF | 25% Office / 65% Lab / 10% Warehouse |
| 3000 Scott Blvd, Ste. 112 & 115 | 2,314 SF | 100% Office |
| 2942-2944 Scott Blvd | 4,040 SF | 30% Office / 10% Lab / 60% Warehouse |
| 3034-3036 Scott Blvd | 4,110 SF | 30% Office / 40% Lab / 30% Warehouse |
| 2928-2932 Scott Blvd | 6,180 SF | |

UPDATED: SEPTEMBER 2021



SITE PLAN

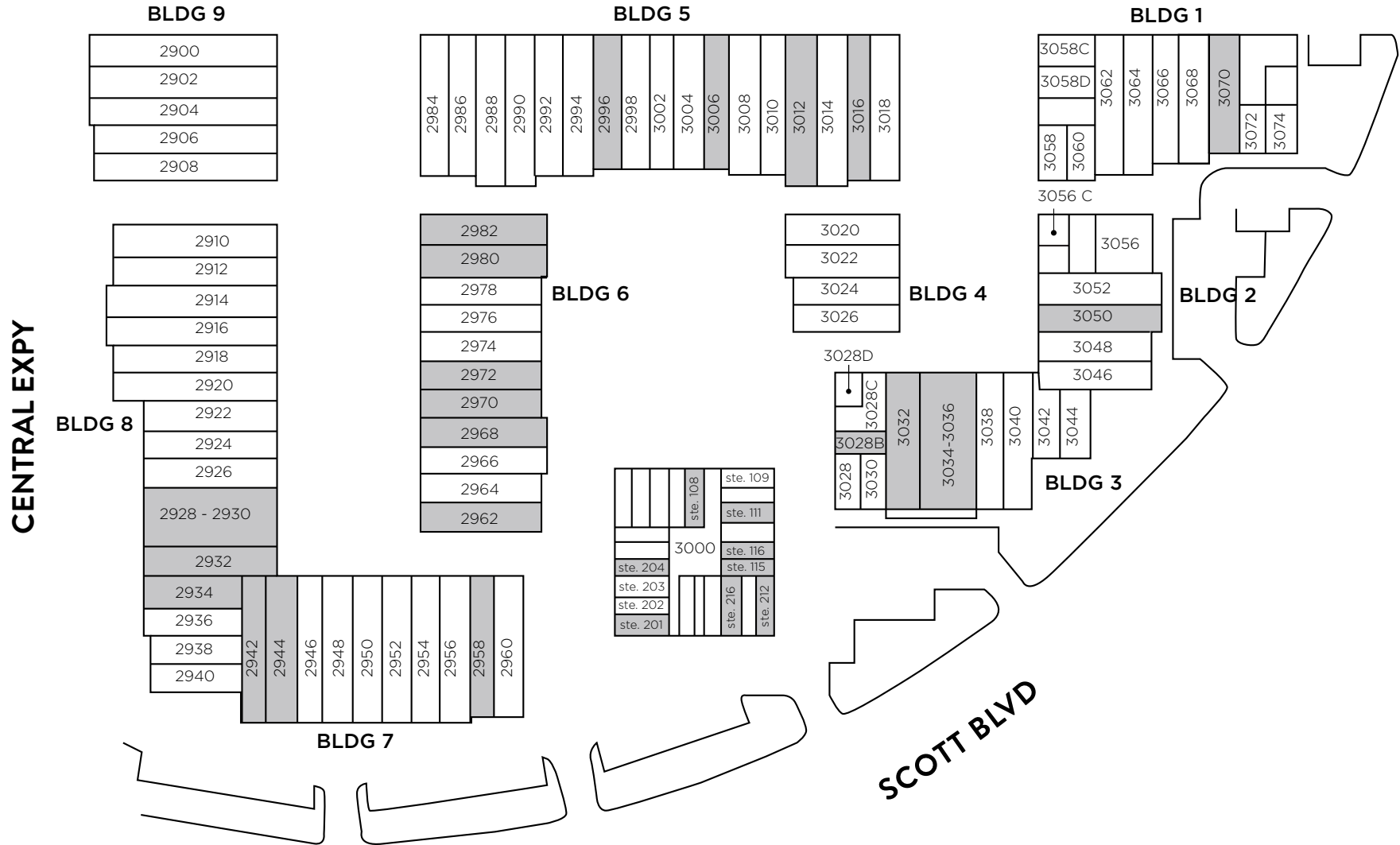

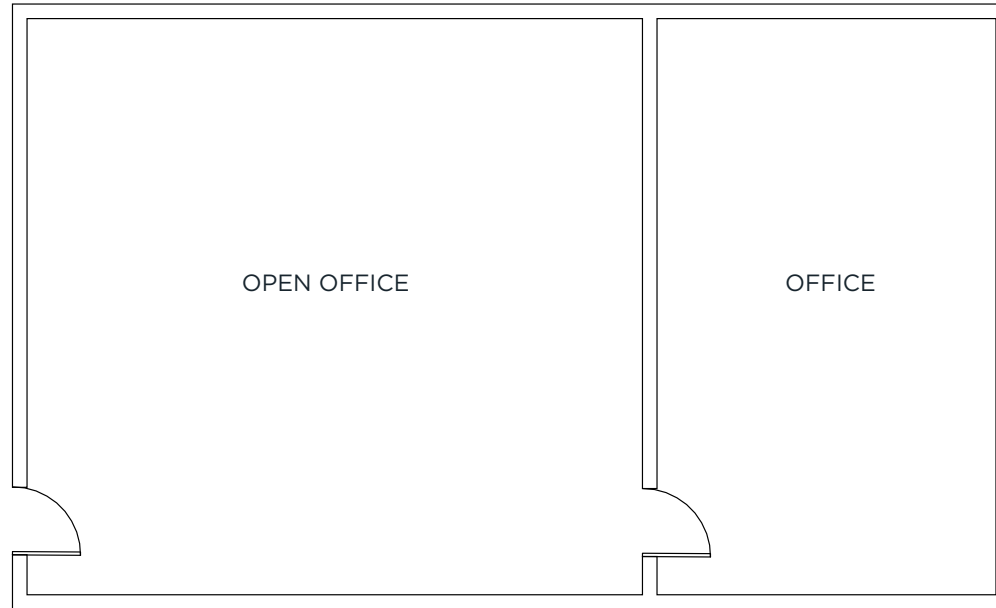

3000 SCOTT BOULEVARD, SUITE 201 | ±545 SF

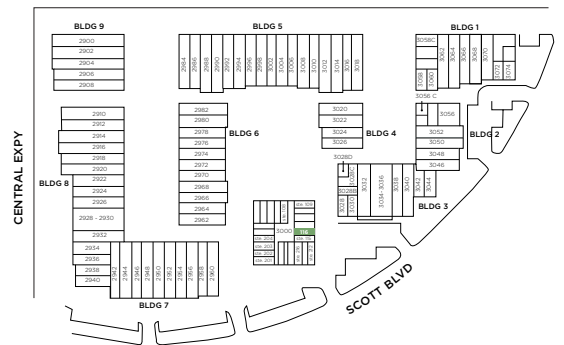
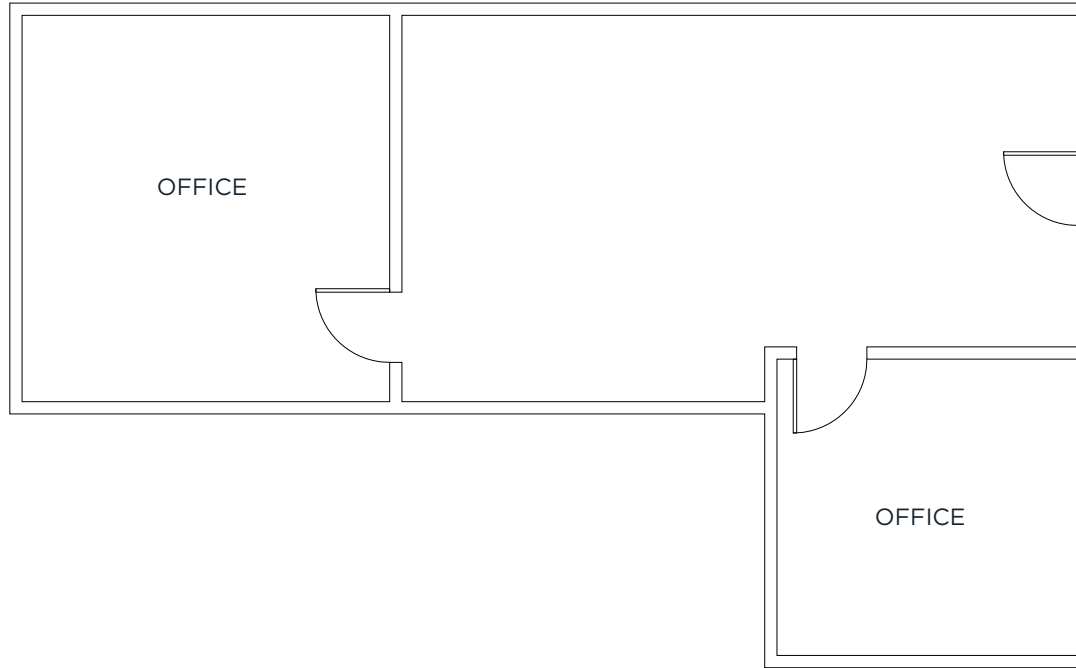

WAREHOUSE
 VCT / DROPPED CEILING

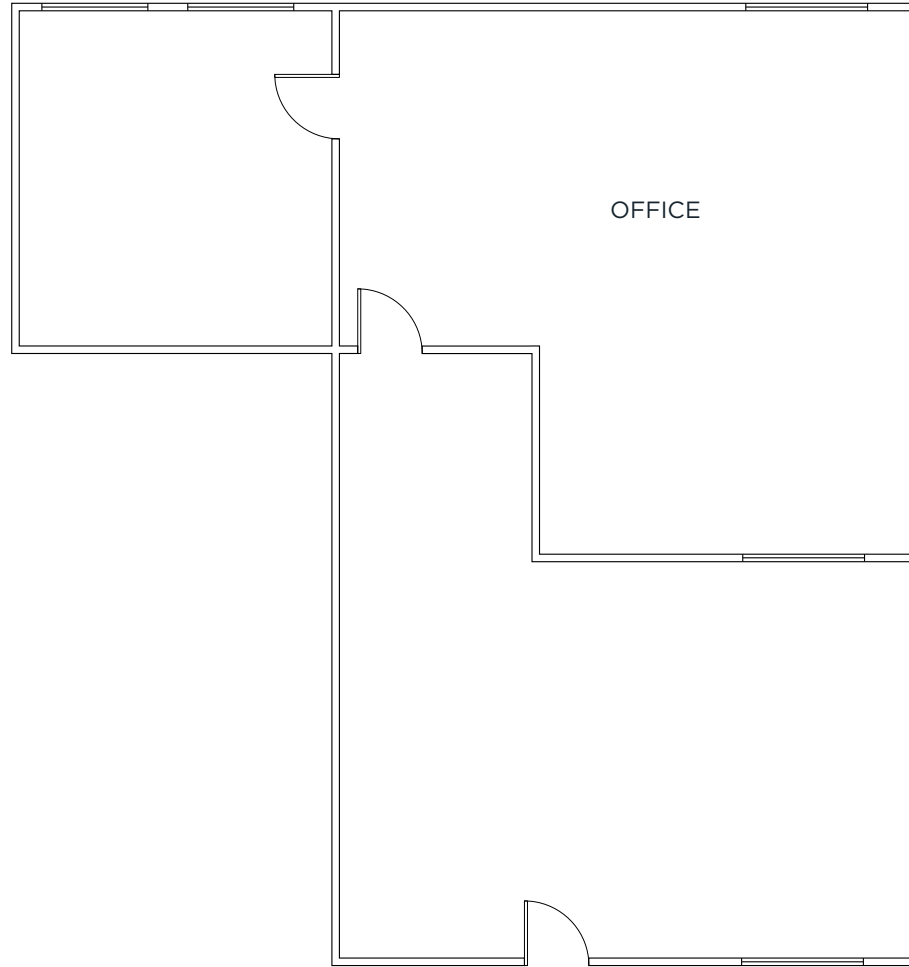

WAREHOUSE
 VCT / DROPPED CEILING



3000 SCOTT BOULEVARD, SUITE 108 | ±647 SF

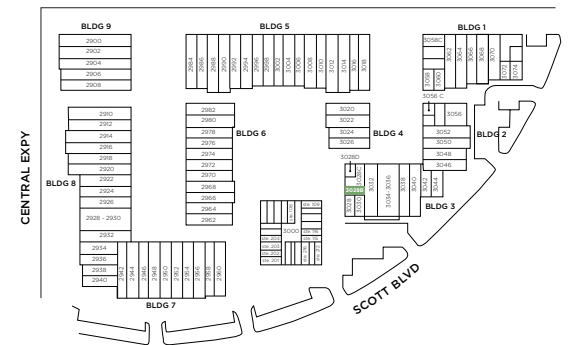
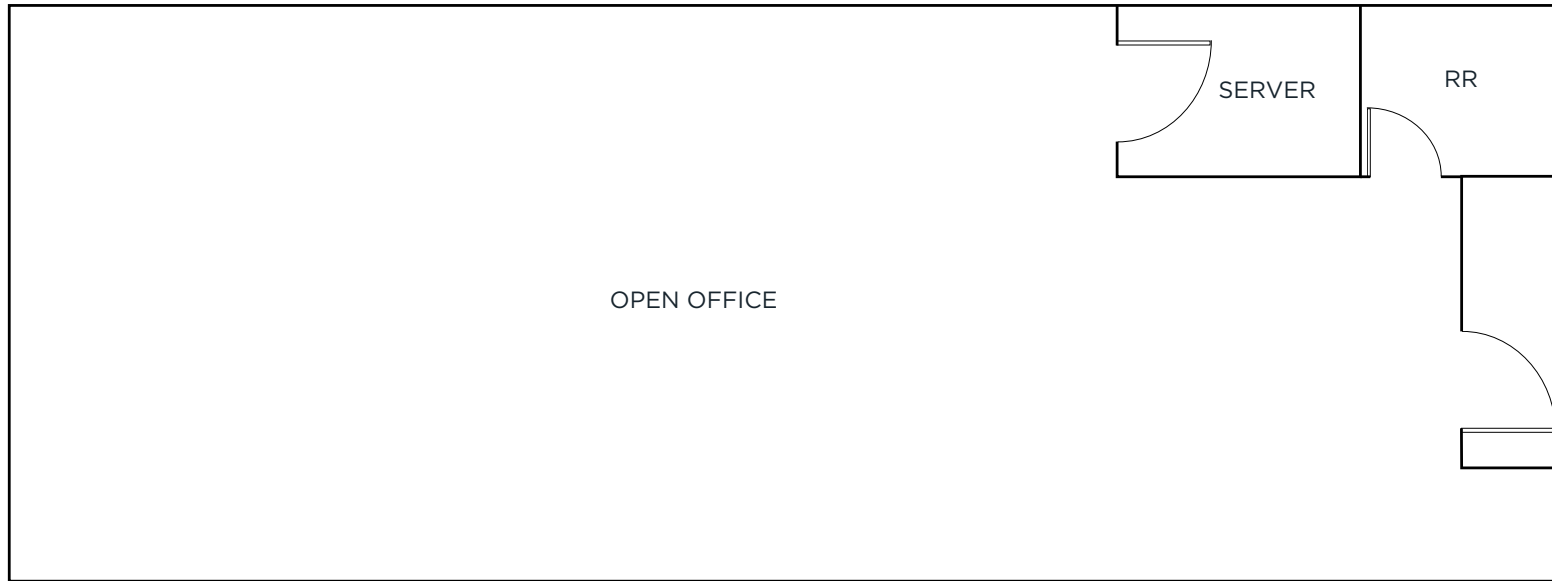

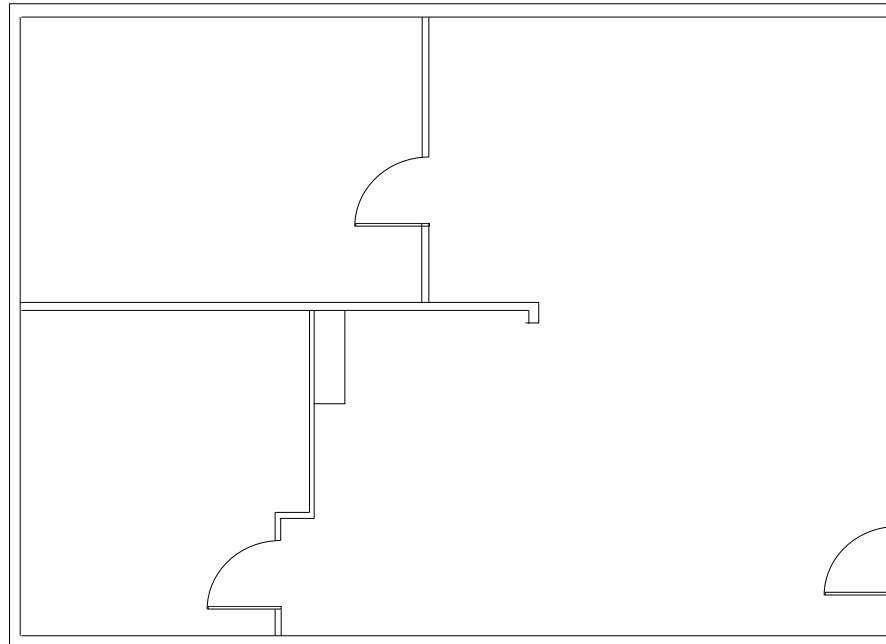

WAREHOUSE
 VCT / DROPPED CEILING

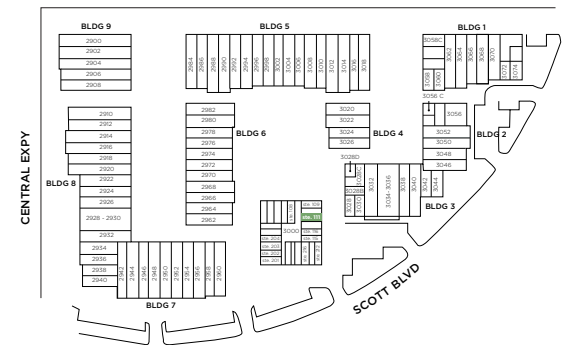

3000 SCOTT BOULEVARD, SUITE 111 | ±986 SF

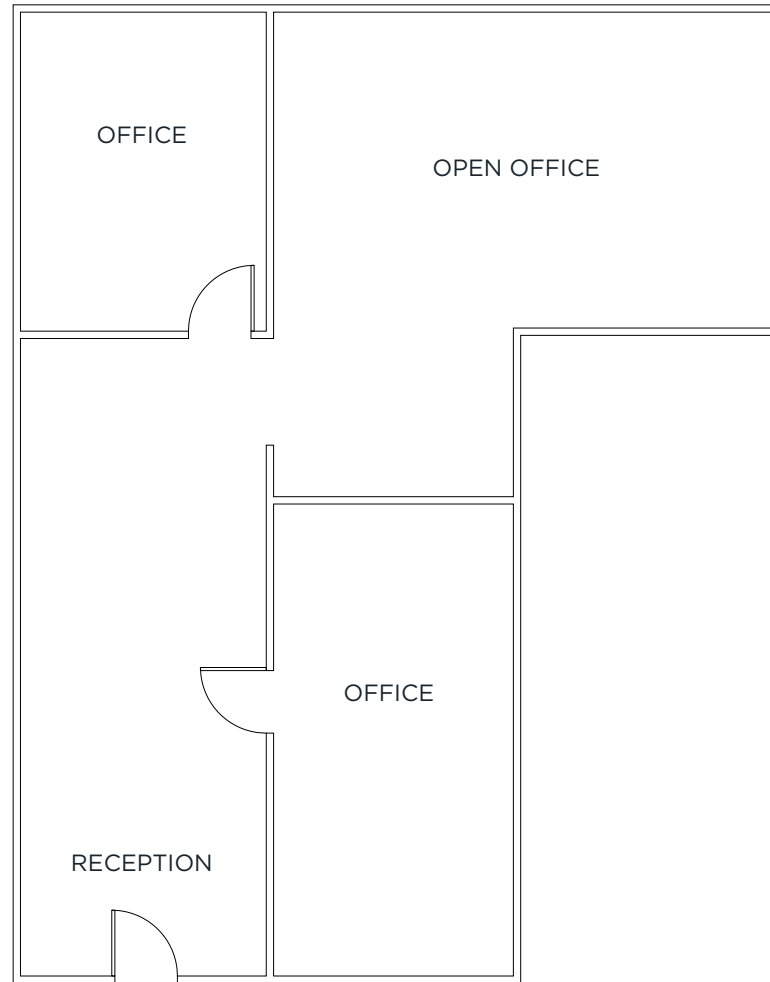

WAREHOUSE
 VCT / DROPPED CEILING



3000 SCOTT BOULEVARD, SUITE 204 | ±1,165 SF

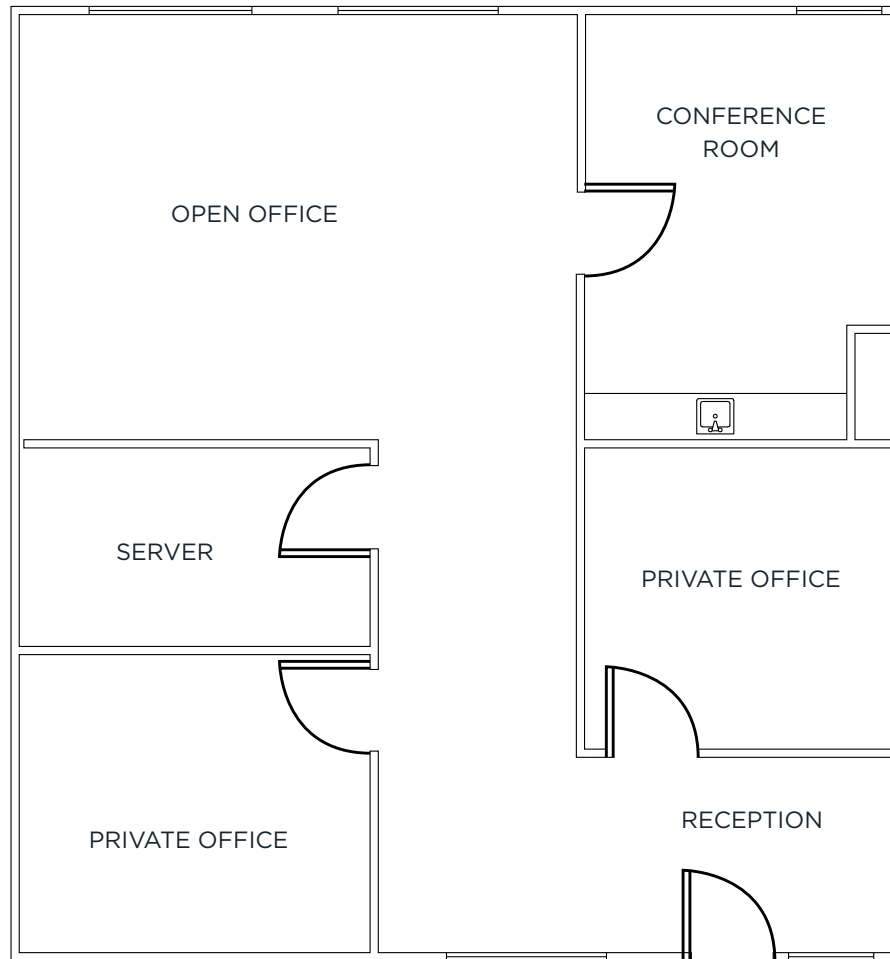

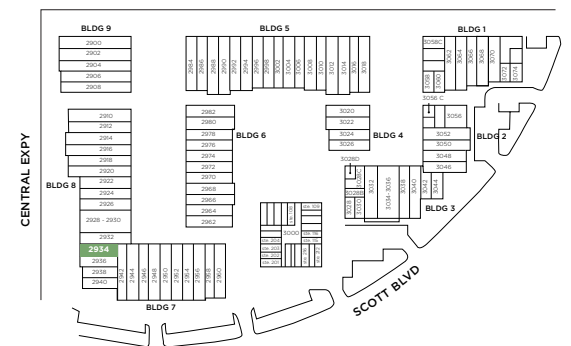
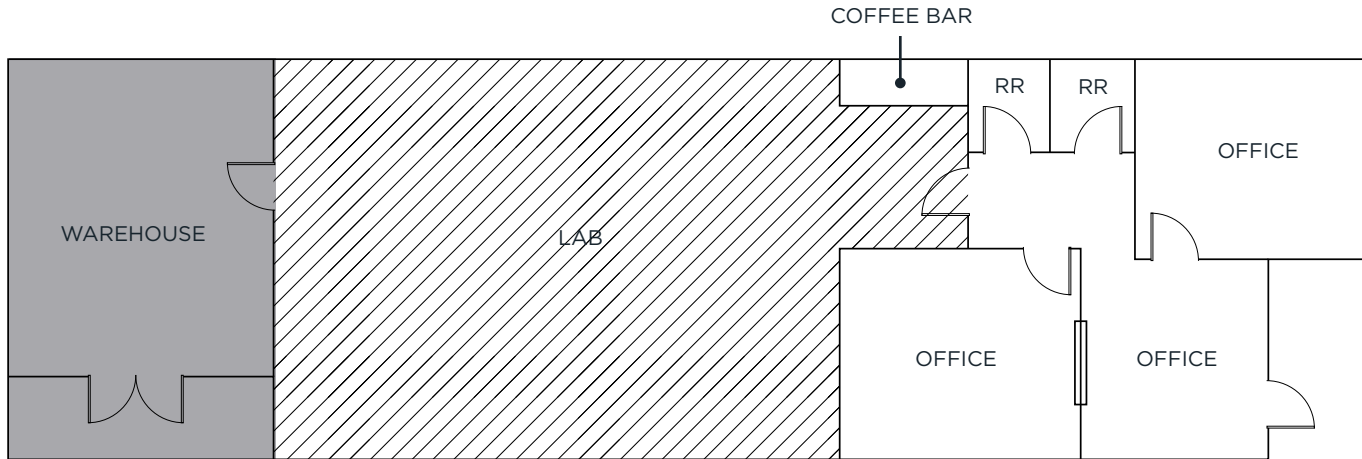

2934 SCOTT BOULEVARD | ±1,410 SF

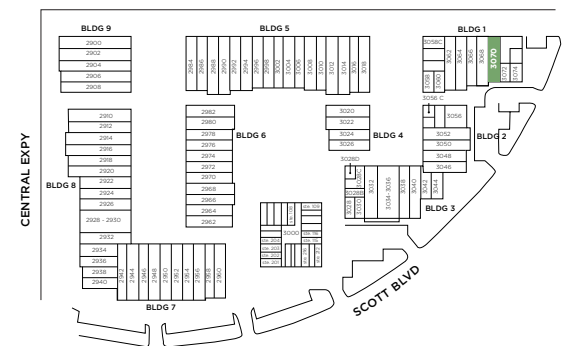
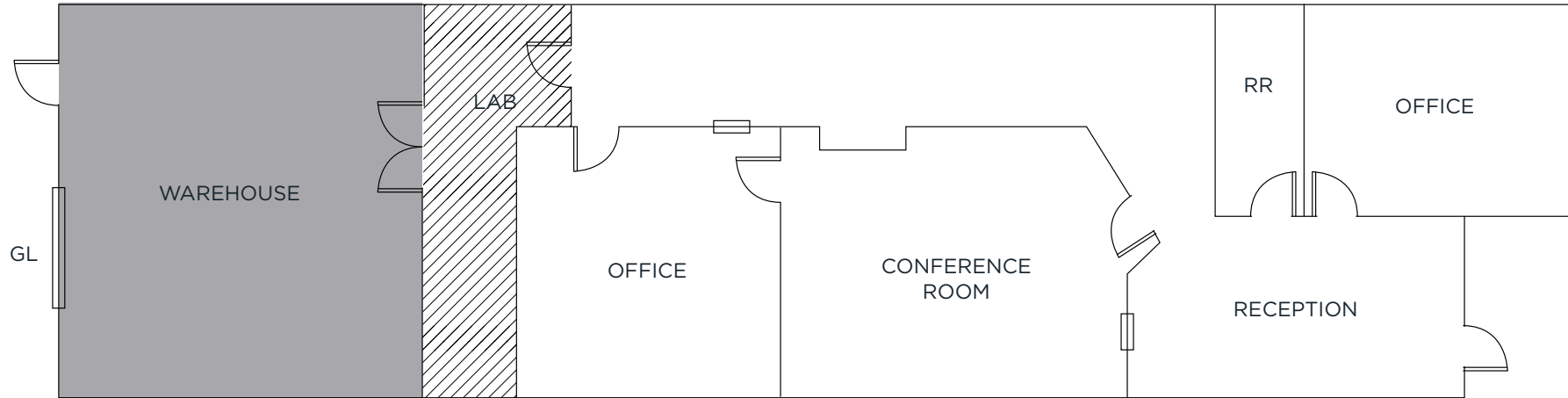

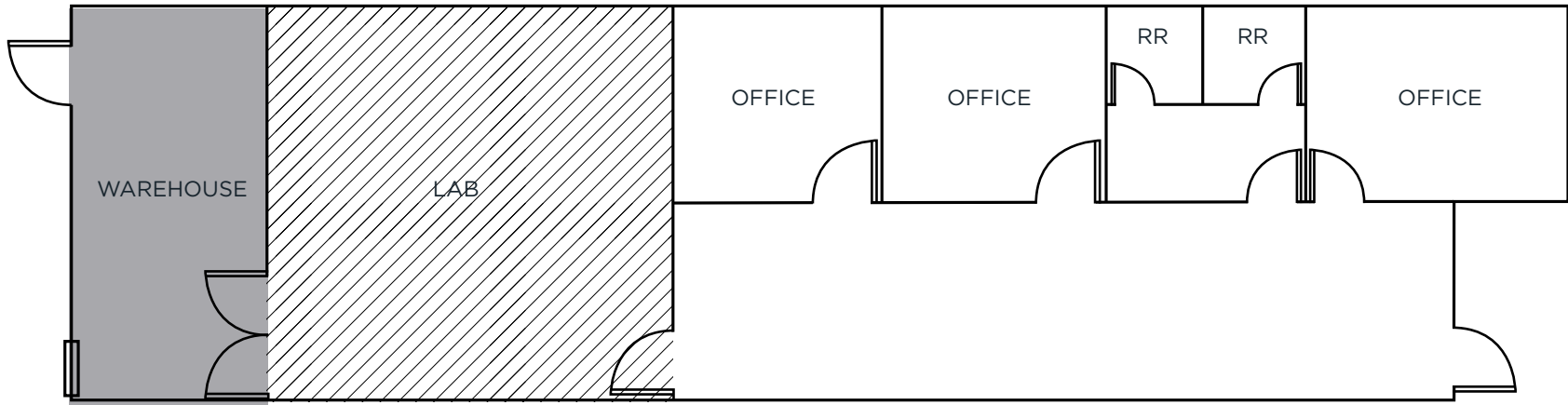

2962 SCOTT BOULEVARD | ±1,680 SF

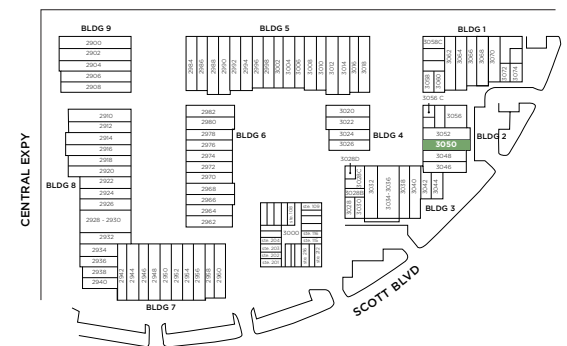
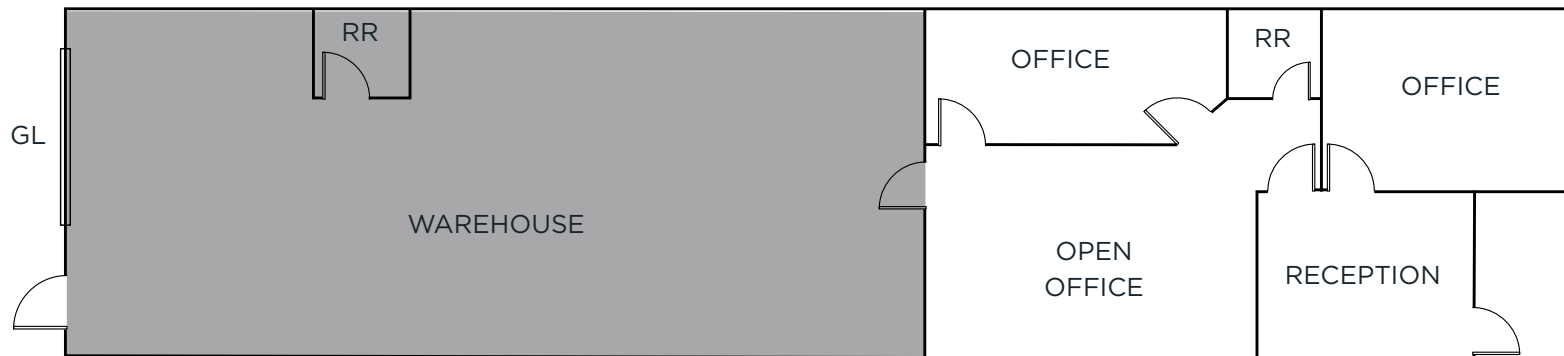

3050 SCOTT BOULEVARD | ±1,740 SF

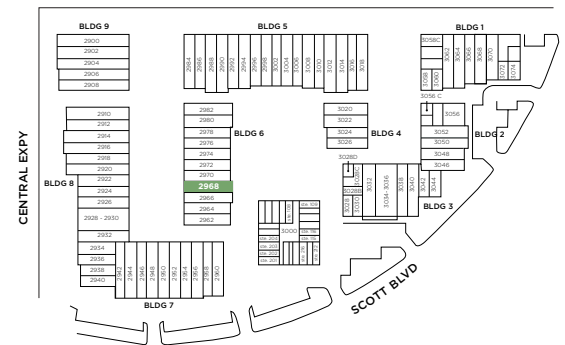
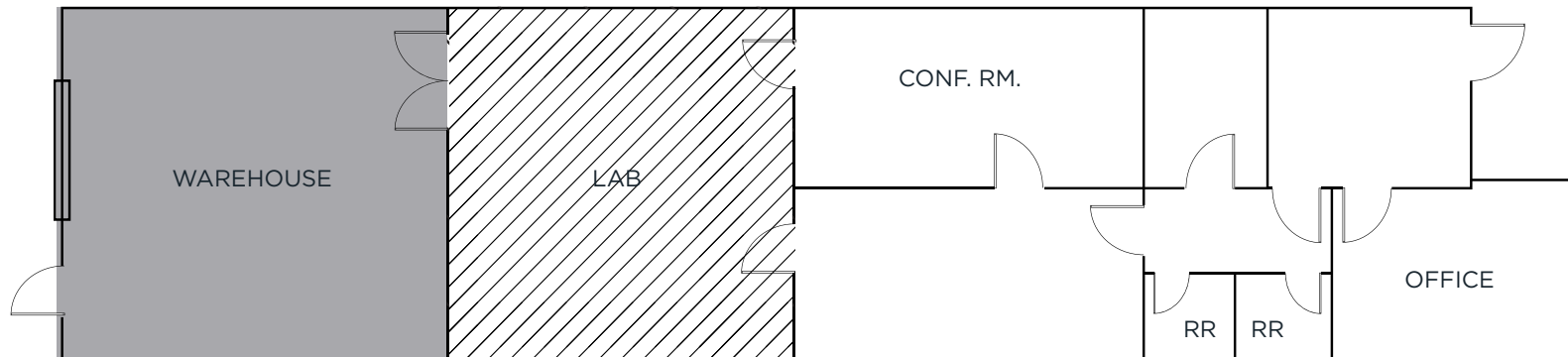

2968 SCOTT BOULEVARD | ±1,780 SF

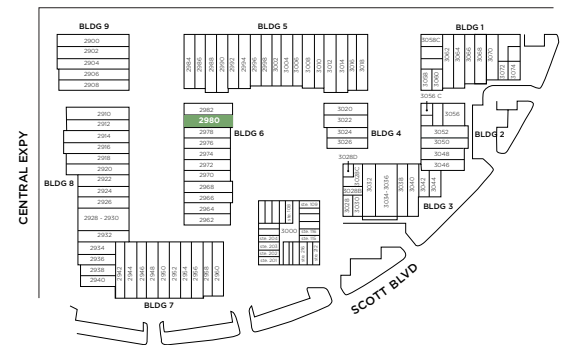
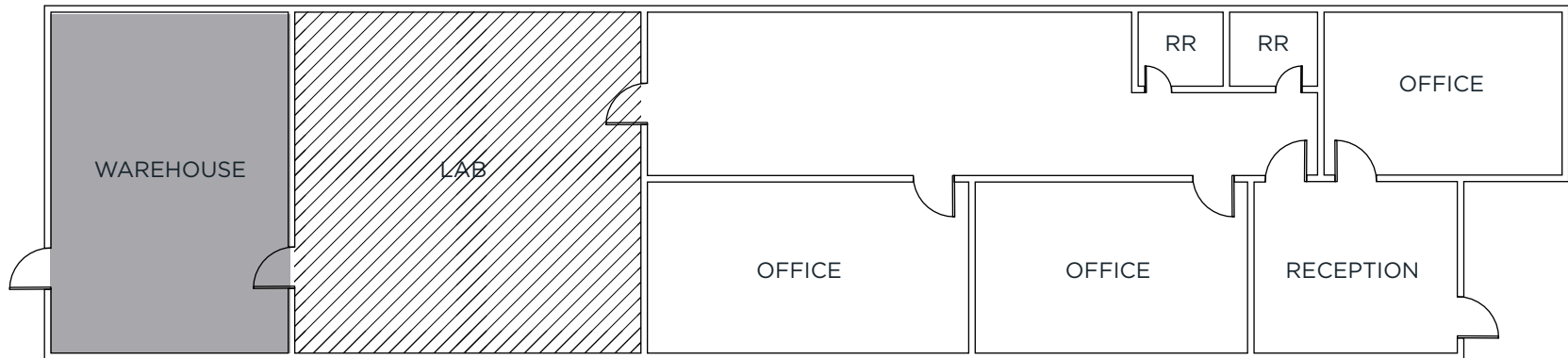

2980 SCOTT BOULEVARD | ±1,780 SF

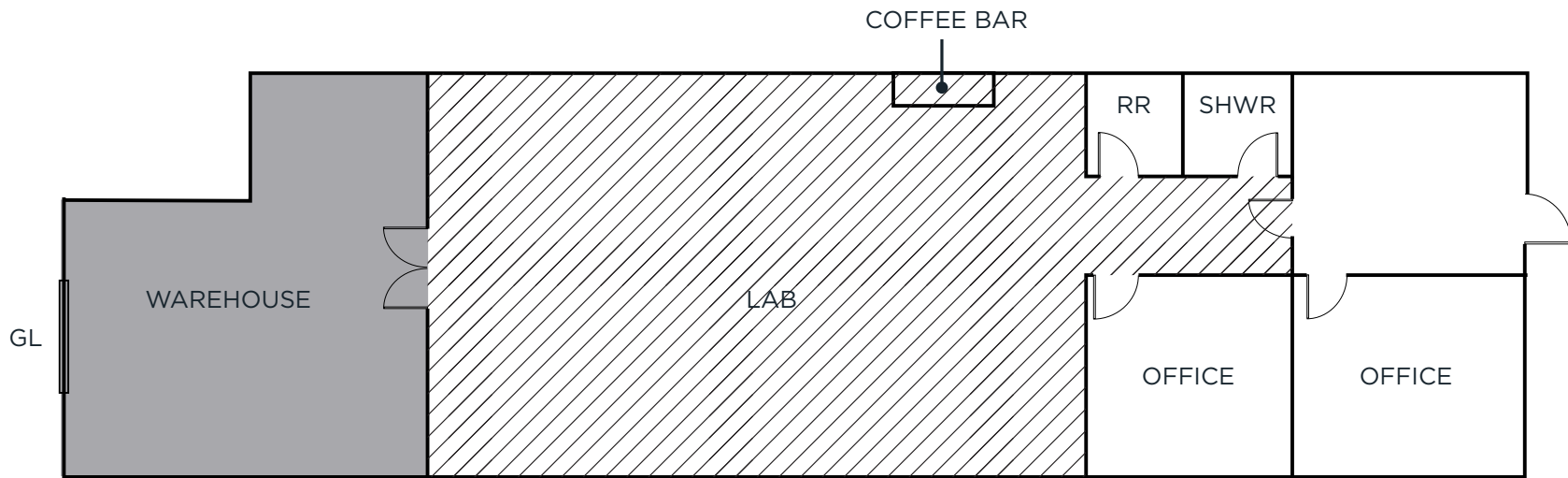

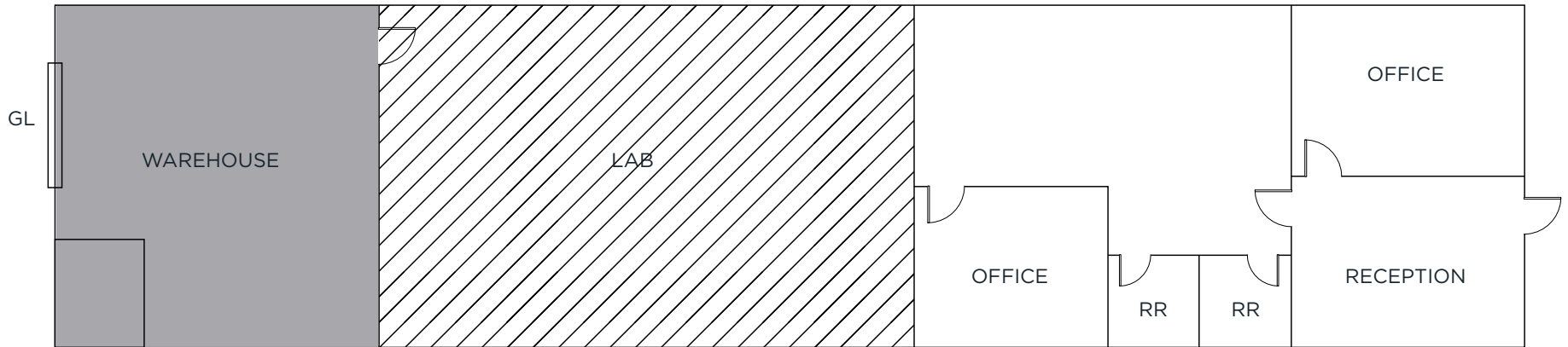

2972 SCOTT BOULEVARD | ±1,820 SF

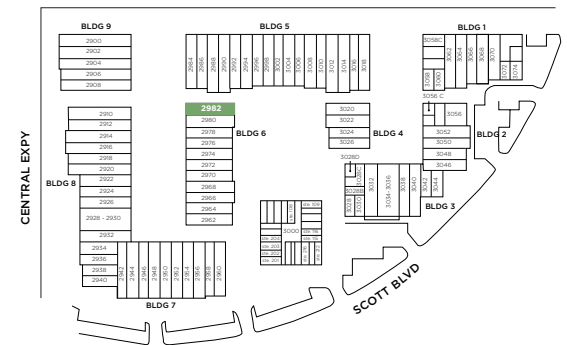
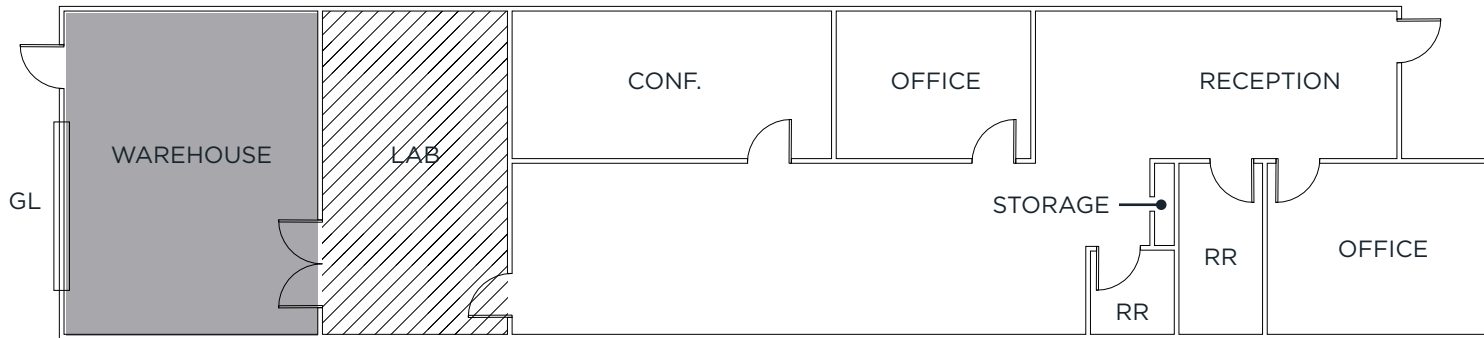

2982 SCOTT BOULEVARD | ±1,830 SF

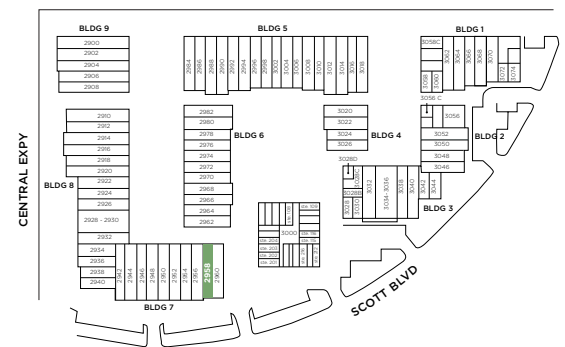
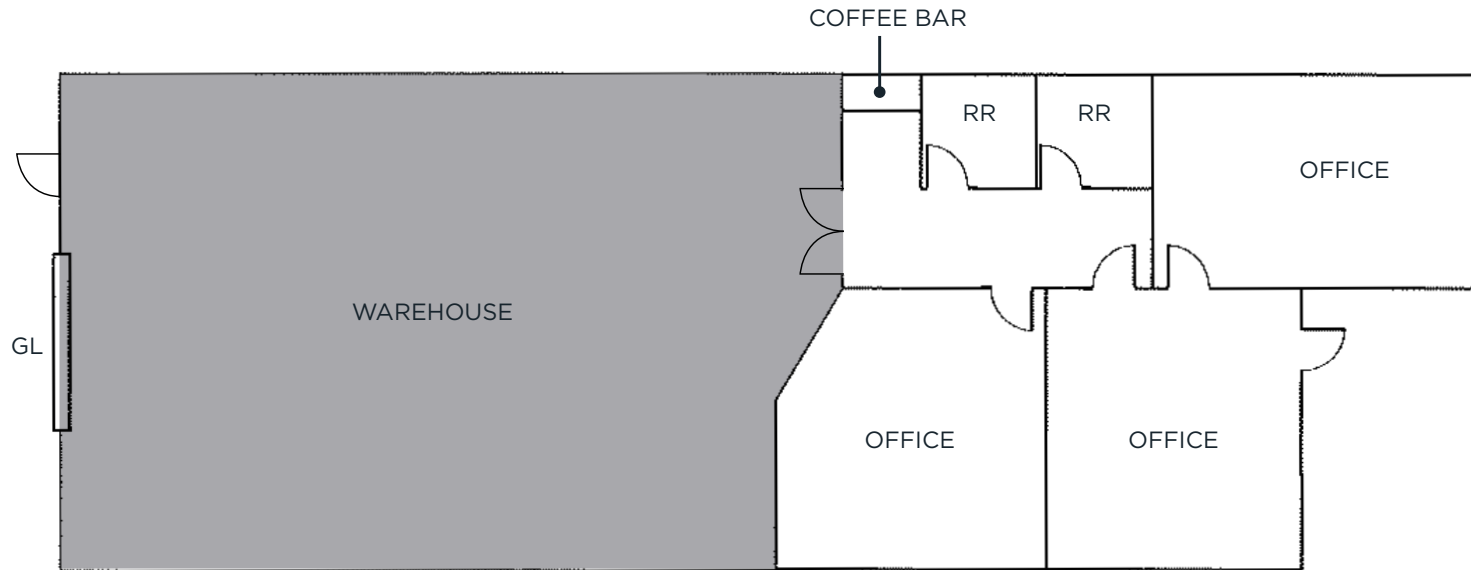

2958 SCOTT BOULEVARD | ±1,918 SF

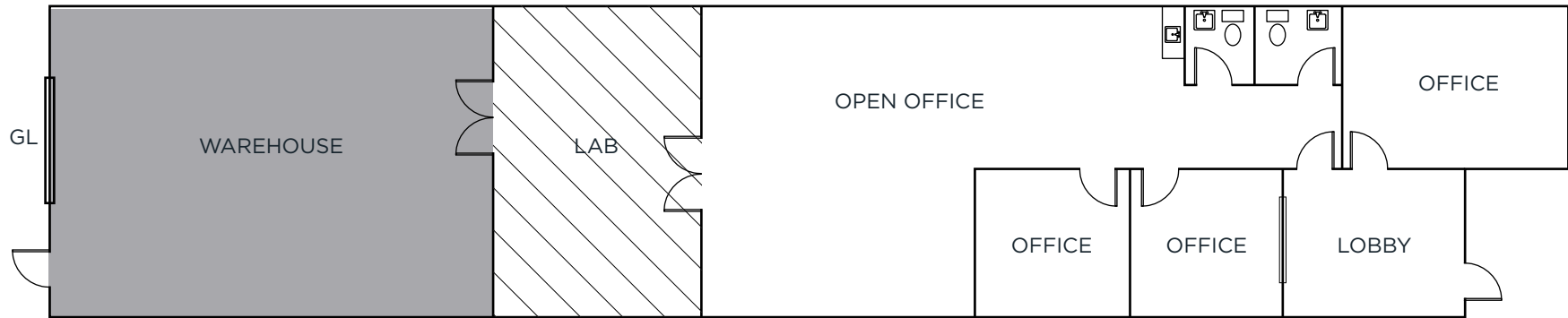

3016 SCOTT BOULEVARD | ±1,940 SF

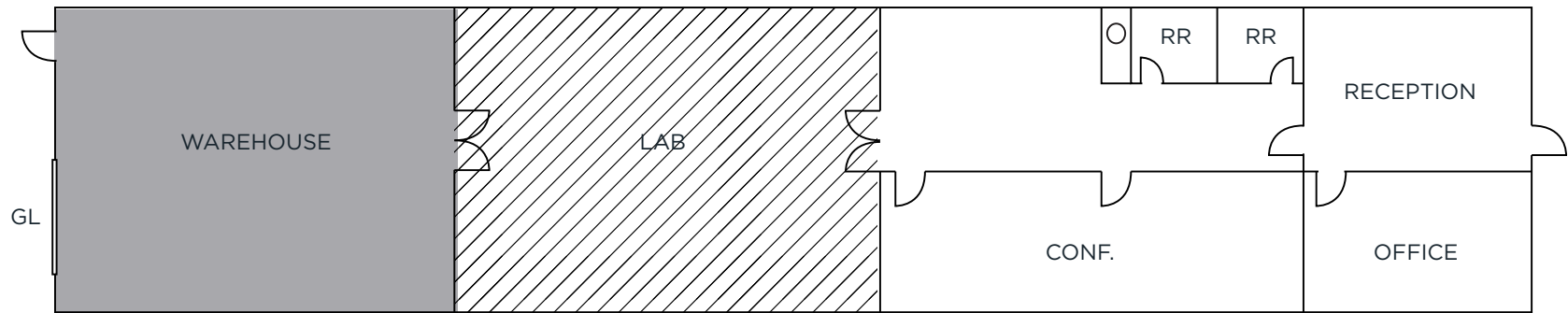

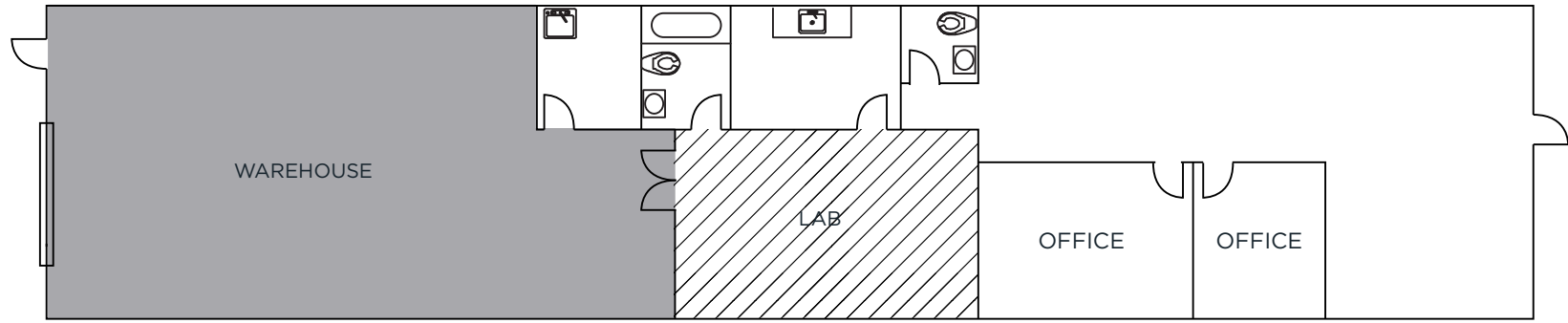

3032 SCOTT BOULEVARD | ±2,030 SF

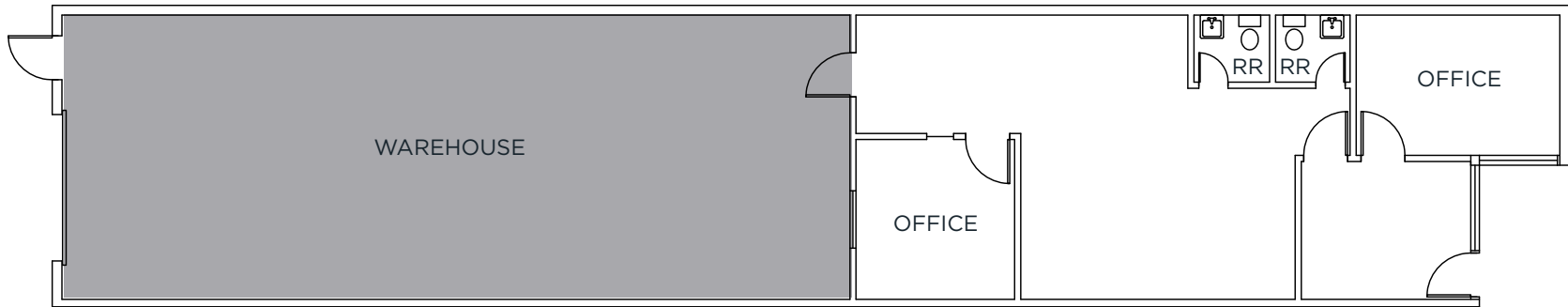

3012 SCOTT BOULEVARD | ±2,060 SF

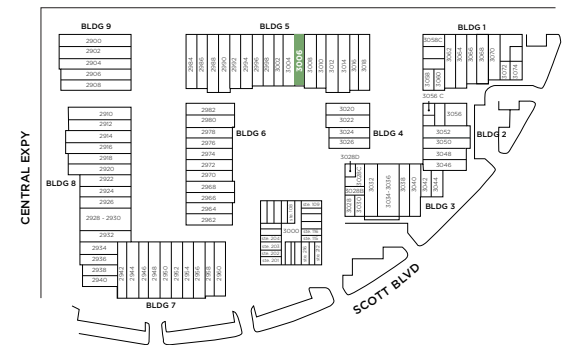
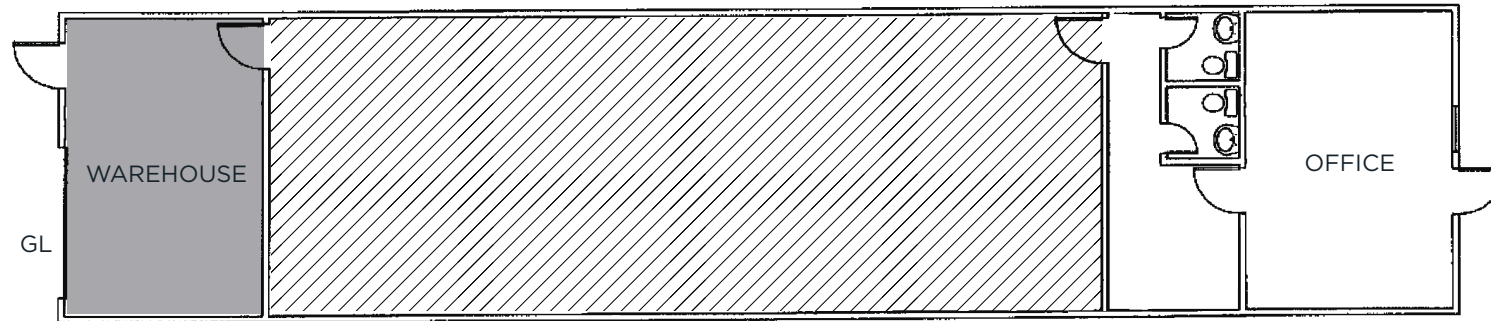

3006 SCOTT BOULEVARD | ±2,063 SF

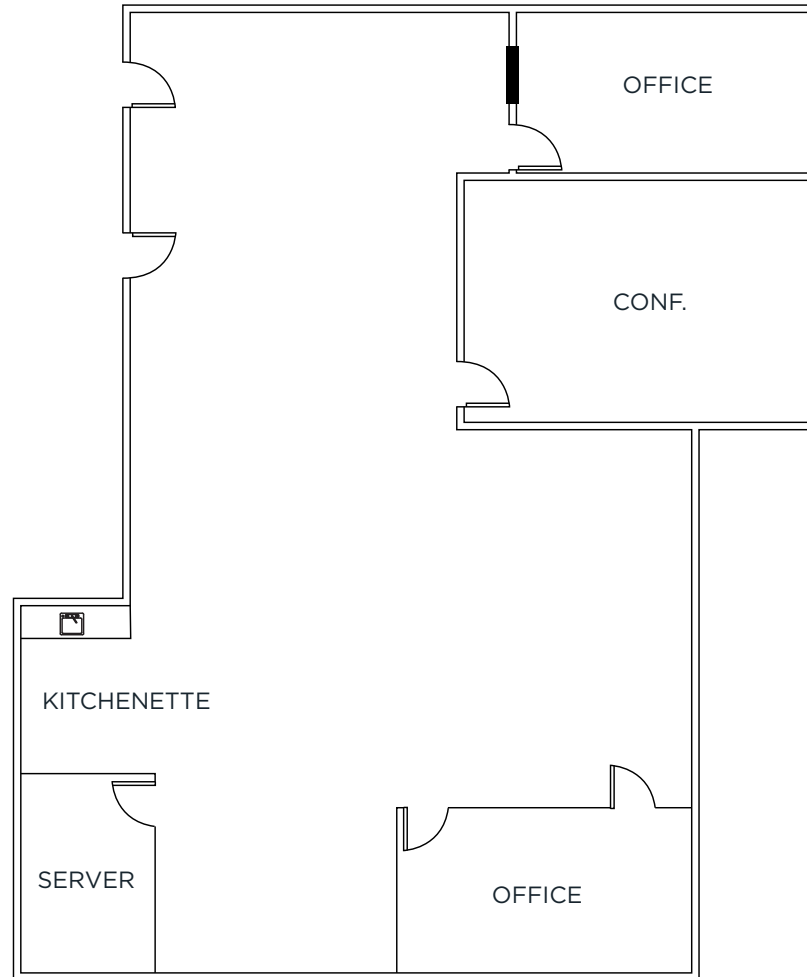

WAREHOUSE
 VCT / DROPPED CEILING

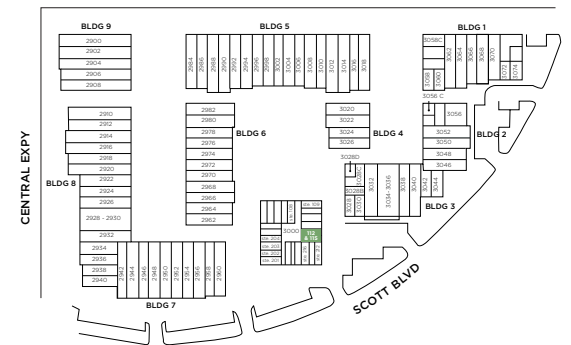

3000 SCOTT BOULEVARD, SUITES 112 & 115 | ±2,314 SF

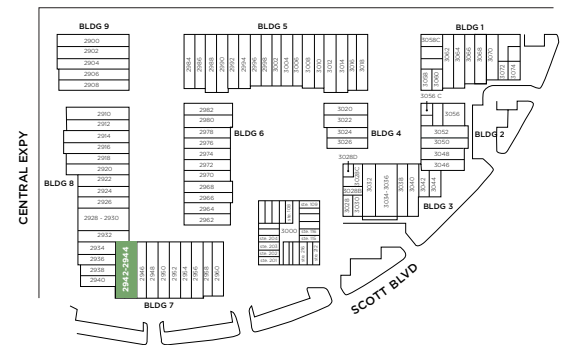
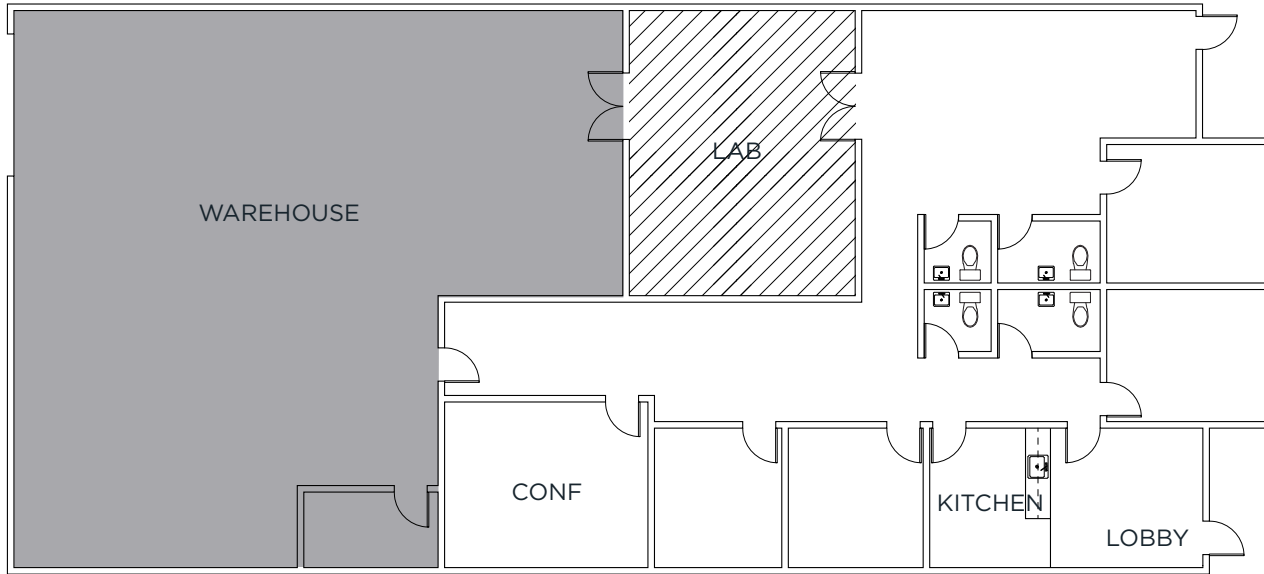

2942-2944 SCOTT BOULEVARD | ±4,040 SF

2932: ±2,120 SF

2928/2930: ±4,060 SF

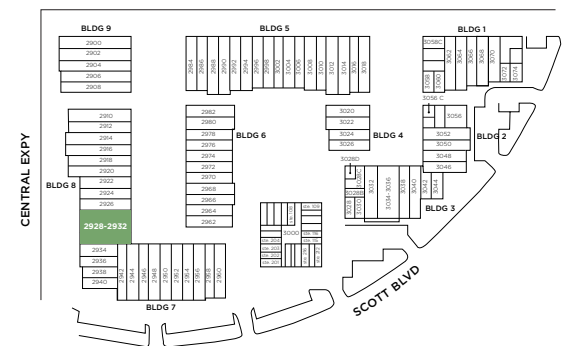
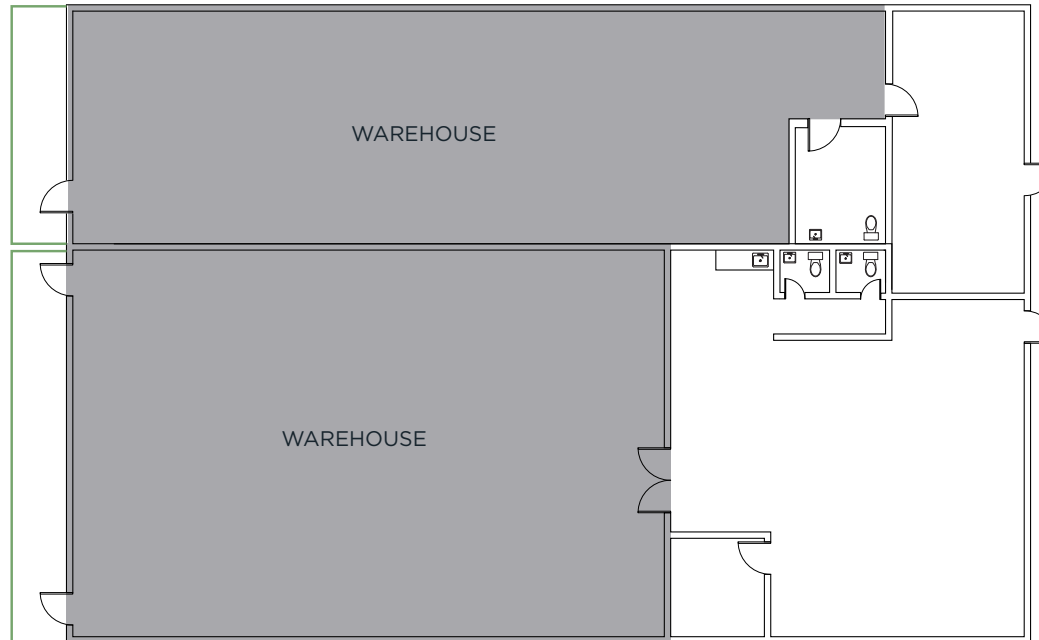

2928-2932 SCOTT BOULEVARD | ±6,180 SF

AMENITIES MAP



RESTAURANTS

- 1 BAMBOO LEAF
- 2 CRESCENT CUISINE
- 3 ATHENA GRILL
- 4 PHO VAN REST & DELI
- 5 MONTAGUE'S CAFE
- 6 SUBWAY
- 7 DELI PLACE 01
- 8 PEDRO'S
- 9 BIRK'S
- 10 SPECIALTY'S
- 11 WHOLE FOODS MARKET
- 12 IN-N-OUT BURGER

RETAIL

- 1 7-ELEVEN
- 2 VILLA MARKET
- 3 WALMART MARKET

BANKING

- 1 BANK OF AMERICA
- 2 US BANK
- 3 COMERICA BANK

GAS STATIONS

- 1 VALERO
- 2 SHELL
- 3 ROTTEN ROBBIE
- 4 SHELL



LOCATION MAP

